

Mach[®] 3

Coin sorter/counter/packager

Efficient coin processing for tabletop or portable applications

The optimization of cash management calls for specialist experience, resources and truly innovative technology. Across the world, Talaris' cash management solutions are trusted by thousands of organizations to ensure their cash is managed securely and efficiently while delivering the ultimate in productivity.

The Mach 3 is a versatile, cost efficient, compact coin processor that simplifies and speeds coin processing for any business that counts, sorts, or packages coin.



With best-in-class speed, Talaris' Mach[®] 3 is a compact commercial grade coin processor that is fast, accurate and versatile.

especially in retail locations where a large number of cashiers are employed. The compact design of the Mach 3 and the optional carrying case make it easy to transport between locations.

Optimal speed and accuracy

The simplicity of the patented Figure 8 technology provides optimal and accurate sorting at 1,500 coins per minute. This makes the Mach 3 one of the fastest in its class.

Versatile options to meet your needs

Coins can be sorted into drawers, bags or tubes for rolling. When the tubing option is used, coin can be sorted first and then rolled by denomination, or it can be done in one easy step. The cash till sorting kit is also a fast way to count tills,

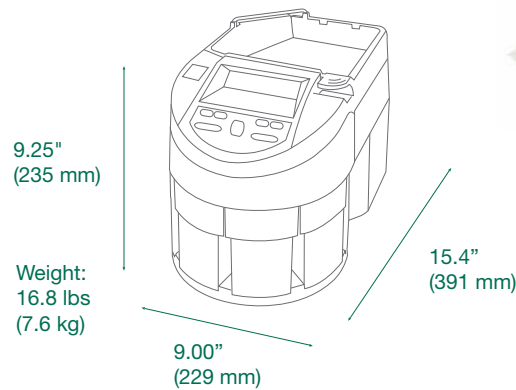

Product specifications

Processing speed	Up to 1,500 coins per minute	Dimensions (H x W x D)	9.25" x 9.00" x 15.4"
Coin size range	Diameter: 0.61" to 1.28" (15.5 mm to 32.5 mm) Thickness: 0.04" to 0.12" (1.0 mm to 3.0 mm) Differential: 0.02" (0.5 mm) minimum	Weight	16.8 lbs
Tilting inspection pan capacity	1,500 coins	Security features	Lock-out security to protect operating information Battery backup in the event of a power failure
Exact bag stops	Standard	Options	Coin drawers, standard and mega Bagging attachments, bagging pedestal Inspection pan magnet kit Printer Soft sided machine cover/carry bag Cash till sorting kit Tubing kits Batch remote display
Connectivity	RS232 and USB standard		
Power supply	90 - 264V AC, 50/60 Hz		

North American Headquarters
2441 Warrenville Road
Lisle, IL 60532
United States
T +1 800.527.2638
www.talaris.com

