

EV8650

Note counter

The fastest note counter in the world

The optimization of cash management calls for specialist experience, resources and truly innovative technology. Across the world, Talaris' cash management solutions are trusted by thousands of organizations to ensure their cash is managed securely and efficiently while delivering the ultimate in productivity.

The EV8650 is the fastest note counter in the world. Its unrivalled durability, accuracy and ease of use create more uptime, low cost of ownership and high productivity.



Commercial grade EV86 Series note counters are designed and built to be fast, accurate and robust. This means you can count your notes efficiently and quickly with few interruptions, saving time and money.

The fastest note counter in the world

EV8650 will accept a range of notes in various conditions because its UltraFeed™ “wing” design helps notes pass through the counter with ease. This minimizes stops caused by the need to re-feed notes that other note counters would not accept. With UltraFeed, you will get superior throughput with EV8650 and the fastest note counting speed in the world.

Accurate feed

The intelligence of Mechanical Doubles Detection™ (MDD) also enhances throughput. This patented technology enables the note counter to recognize and accurately count doubles or chain notes that overlap during feeding.

Robust build and a premium look and feel

From the metal side plates and sheet metal running through the heart of the machine, to the ergonomic handle and user-friendly keypad, EV8650 is a robust and reliable note counter. EV8650, with its premium look and feel, is the best choice for all your note counting needs.

Talaris’ note processing products are the direct result of over 100 years of experience in the design, manufacturing and distribution of world class note processing machines.

Talaris Technology
Talaris' unique technology sets new industry standards

UF™
ultra feed

Maximizing feed efficiency, ensuring that all banknotes are fed consistently irrespective of design and quality of condition.

MDD™
mechanical double detection

Right. First Time. Every Time.
Most accurate counting technology in the world.
Decisive counting; low stop-rates.
Less re-feeding, less frustration.

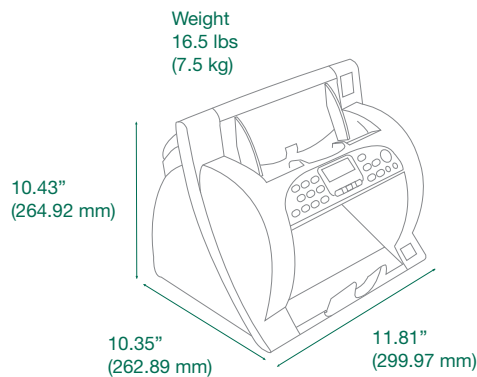

Product specifications

Speed range	800 - 2000+ notes per minute	Connectivity	RS232 for PC or printer connection standard
Feed technology	UltraFeed™	Dimensions (H x W x D)	10.43" x 11.81" x 10.35"
Count accurate technology	Mechanical Doubles Detection™ (MDD)	Weight	16.5 lbs
Capacity	Feed Hopper = 500 notes Output Stacker = 200 notes	Power supply	98 – 264V AC, 50/60 Hz
Keypad	Numeric keypad with full travel keys	Models	8650 Std (US only) 8650 UV (Canada only)

North American Headquarters
2441 Warrenville Road
Lisle, IL 60532
United States
T +1 800.527.2638
www.talaris.com

