

# CountEasy™

Count-by-weight cash counter  
Count a cash drawer in under one minute

The optimization of cash management calls for specialist experience, resources and truly innovative technology. Across the world, Talaris' cash management solutions are trusted by thousands of organizations to ensure their cash is managed securely and efficiently while delivering the ultimate in productivity.

CountEasy provides a low-cost, quick and easy way for financial institutions, restaurants and retailers to count notes and coins.



CountEasy uses a count-by-weight method, in conjunction with highly accurate weighing technologies, to FlashCount™ notes and coin. It provides you with accurate end-of-day drawer or safe balancing and accurate audits throughout the day. CountEasy is perfect for banks, credit unions, restaurants and retail stores that need a low-cost, reliable way to manage notes and coin. It is also great for preparing start funds.

### Simple and convenient

CountEasy handles both loose or rolled coins and loose or banded notes. Users move quickly through their counting process from one denomination to the next — conducting a cash drawer count in less than one minute.

CountEasy has an extendable back to handle larger volume note stacking or coin bags, complete with a specially designed recess for coin roll positioning. It comes with the ergonomic FlexiCup™, which is ideal for easily transferring coin from CountEasy to a bag without spills. CountEasy can also be configured to use a wide range of other till cups.

### Compact and reliable

CountEasy plugs into an outlet or can be powered using standard rechargeable AA batteries. The compact, lightweight design and carrying grip make it the perfect choice for users requiring portability.

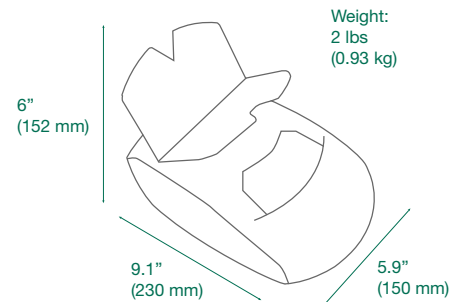

## Product specifications

Counting range	Notes, coins and other items	Standard features	FlexiCup™ Extendable back Integrated handle Rechargeable battery
Power Supply	External: 00-240V~50/60Hz 0.45A Batteries: User replaceable, 6 x 1300mA NiMH AA pack	Options	Thermal printer Till cup inserts

North American Headquarters  
2441 Warrenville Road  
Lisle, IL 60532  
United States  
T +1 800.527.2638  
www.talaris.com

