

Benchmark Series[®] 7

Cash dispenser

Speed up transactions and increase cash security

The optimization of cash management calls for specialist experience, resources and truly innovative technology. Across the world, Talaris' cash management solutions are trusted by thousands of organizations to ensure their cash is managed securely and efficiently while delivering the ultimate in productivity.

The Benchmark Series 7 cash dispenser from Talaris quickly and accurately dispenses cash, enhancing the client's experience and improving operating efficiencies. By eliminating tedious manual cash counting, wait times are shorter, and staff has more time to focus on customer service, cross-selling and other critical activities.



The Benchmark Series 7 cash dispenser from Talaris quickly and accurately dispenses cash, enhancing the client's experience and improving operating efficiencies.

Lower total cost of ownership

Benchmark Series 7 employs a dispensing mechanism built for high volume transactions. This results in greater equipment up-time, less service calls, and a better

staff experience, as tellers continue assisting customers. Because Benchmark is purpose-built, it is one of the most reliable dispensers on the market. Coupled with Talaris' top rated service, it is the risk-free choice.

Increase security, eliminate theft

Benchmark Series 7 offers vault-level security and eliminates cash exposure — significantly reducing theft risk and improving the security of clients and staff.

Improve transaction efficiencies and enhance the client experience

Accuracy and speed are what clients look for when conducting cash transactions; Benchmark Series 7 provides both. Its flexible configuration options ensure your individual needs can be met. Select from the 730 or 750 client dispense models, and a wide range of cassette, drop box and security options that fit your needs.

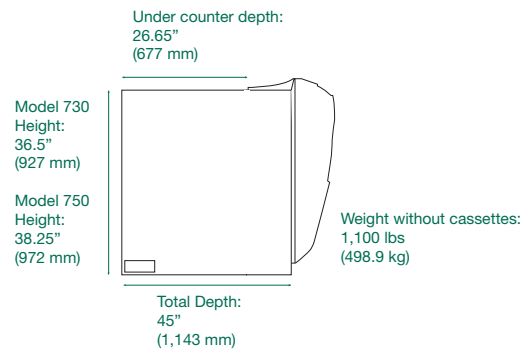
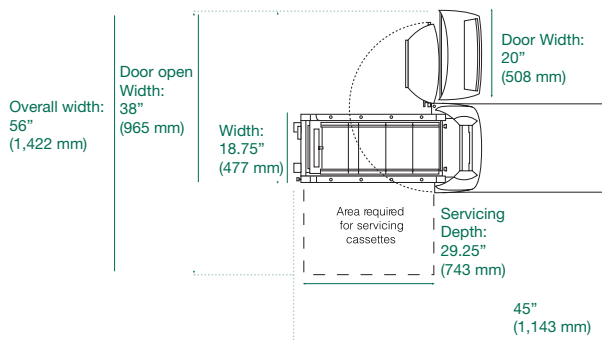

Weight and dimensions shown are for UL 291 24 hrs Level 1 safe. Data for other configurations will vary. Please contact your account manager for details.



Product specifications

Dispense speed	Model 730 - up to 10 notes per second Model 750 - up to 15 notes per second	Power supply	115 - 230V AC 50/60Hz
Note capacity	Model 730 - 1,600 notes per module Model 750 - 2,000 notes per cassette	Security	UL rated 24-hour Level 1 steel chest door protected by concealed dual control lock with alarm (door contact, heat sensor, vibration)
Number of denominations	Up to 6	Options	PC upgrades Teller Cash Connect (TCC) Manager Cassette level security Several security lock options Data Display InstaChange® coin dispenser Client Dispense with rear service door Deposit drop box
Dispense bundle size	Model 730 - 75 notes Model 750 - 100 notes		
Cassettes	Model 730 - built-in cassette Model 750 - latching, keylocking or electronic locking cassettes		
Connectivity	TCP/IP, Serial, USB API's for Windows, DOS, OS/2, UNIX Connectivity (TCP/IP, Serial, USB)		

North American Headquarters
2441 Warrenville Road
Lisle, IL 60532
United States
T +1 800.527.2638
www.talaris.com

